

DESCRIPTION

The ASI6622 is a professional PCI-Express sound card designed for use in radio broadcast automation.

Providing 6 play streams that are mixed to 2 balanced stereo outputs and 4 record streams fed from 2 balanced stereo inputs, the ASI6622 features AudioScience's unique "anything to anywhere" mixing and routing.

The ASI6622 provides both balanced analog and AES/EBU inputs and outputs. The maximum analog input and output level is +24dBu.

A choice of uncompressed PCM, MPEG layer 2 and MP3 is available for both recording and playback. All compression is handled by an on-board floating point DSP, allowing the host computer to focus on other tasks.

ASI6622 functionality includes MRX™ multi-rate mixing technology, which allows streams of different, sample-rates and formats to be mixed digitally. TSX™ time scaling allows compression/expansion of any or all playback streams in real time with no change in pitch.

FEATURES

- 4/6 mono/stereo streams of playback into 2 stereo outputs
- 4/2 mono/stereo streams of record from 2 stereo inputs
- Formats include PCM, MPEG layer 2 and MP3 with sample rates to 96kHz
- MRX™ technology supports digital mixing of multiple stream formats and sample rates
- TSX™ time scaling allows compression/expansion of play streams by up to +/-20% with no pitch shift
- Balanced stereo analog inputs and outputs with levels to +24dBu
- 24bit ADC and DAC with 110dB SNR and 0.0015% THD+N
- AES/EBU inputs and outputs with sample rate converters on all inputs
- Dedicated AES/EBU and Word clock Sync input
- SoundGuard™ transient voltage suppression on all I/O
- Short length PCI card format (6.6 inches/168mm)
- Up to 4 cards in one system
- Windows 2000, XP and Linux software drivers available



ASI6622

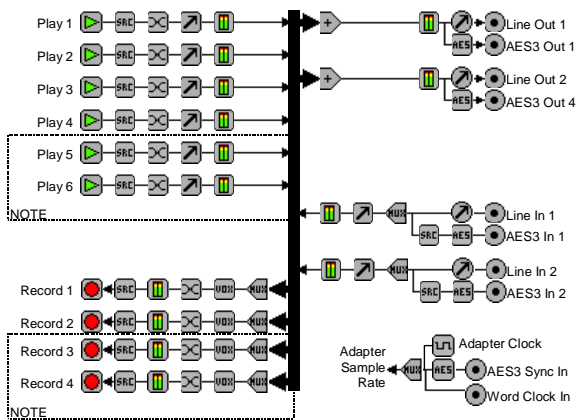

NOTE: Available in 6 Play/4 Record stream mode

- Key:
- Record Stream
 - ▶ Play Stream
 - ⊙ Input/Output
 - ▽ Volume
 - ⊕ Level
 - ⊕ Mixer
 - ⊕ Multiplexer
 - ⊕ AES/EBU Tx/Rx
 - ▬ Meter
 - ⊕ SRC Sample Rate Converter
 - ⊕ Channel Mode
 - ⊕ Clock Source

1. SPECIFICATIONS

ANALOG INPUT/OUTPUT

Type	Balanced
Connector	Mini50 (SCSI-II type)
Input Level	-10 to +24dBu in 0.5dBu steps
Input Impedance	10K ohms
A/D converter	24bit oversampling
Output Level	-10 to +24dBu in 0.5dBu steps
D/A converter	24bit oversampling
Load Impedance	600ohms or greater
Dynamic Range [1]	>110dB (record or play)
THD+N [1]	<-96dB (0.0015%) (record or play)
Frequency Response	20Hz to 20kHz +0/-0.2dB 20Hz to 40kHz +0/-3dB
Inter-channel Phase	<0.1 degrees (record or play)
Inter-channel Crosstalk	>110dB (record or play)

DIGITAL INPUT/OUTPUT

Type	AES/EBU (EIAJ CP-340 Type I / IEC-958 Professional)
Input/Output Impedance	110 ohms
Connector	Mini26 (SCSI-II type)
Sample Rates	32, 44.1, 48, 88.2 and 96kHz with sample rate converters on inputs

SAMPLE RATE CLOCK

Internal (Adapter)	32, 44.1 48, 88.2 and 96kHz
AES/EBU Sync In	32, 44.1 48, 88.2 and 96kHz on dedicated AES/EBU input
Word In	32, 44.1 48, 88.2 and 96kHz
Word Out	32, 44.1 48, 88.2 and 96kHz

SIGNAL PROCESSING

DSP	Texas Instruments TMS320C6713@300MHz
Memory	8MB
Audio Formats	8 bit unsigned PCM 16 bit signed PCM 32 bit floating point PCM MPEG-1 Layer 2 MPEG-1 Layer 3(MP3) (MPEG Layer-3 audio coding technology licensed from Fraunhofer IIS and THOMSON multimedia)

BREAKOUT CABLES (NOT INCLUDED)

Analog	CBL1004: Mini 50 to Centronics 50 adapter. CBL1044: Centronics 50 to 8 in and 8 out XLR.
Digital	CBL1101: Mini 26 to Centronics 50 adapter. CBL1114: Centronics 50 to 1 in, 4 out XLR, 1 BNC in, 1 BNC out (Word Clock).

GENERAL

Bus	X1 PCI-Express.
Dimensions	PCI short-length form factor (6.6 inches/168mm long).
Weight	8 oz (227g) max
Operating Temperature	0C to 70C
Power Requirements	+3.3V@1.5A +12V @ 300mA

[1] – Dynamic Range and THD+N measured using a +20dBu 1kHz sine wave sampled at 48kHz and A weighting filter.

<end>