

## DESCRIPTION

The ASI6640 is a professional PCI-Express sound card designed for use in radio broadcast automation.

Providing 12 play streams that are mixed to 4 balanced stereo outputs and 8 record streams fed from four balanced stereo inputs, the ASI6640 features AudioScience's unique "anything to anywhere" mixing and routing.

The ASI6640 provides both balanced analog inputs and outputs. The maximum analog input and output level is +24dBu.

A choice of uncompressed PCM, MPEG layer 2 and MP3 is available for both recording and playback. All compression is handled by an on-board floating point DSP, allowing the host computer to focus on other tasks.

ASI6640 functionality includes MRX™ multi-rate mixing technology that allows streams of different sample-rates and formats to be mixed digitally. TSX™ time scaling allows compression/expansion of any or all playback streams in real time with no change in pitch.

For emerging surround sound applications, SSX™ mode allows multichannel streams of up to 8 channels to be played, recorded and mixed.



PCI EXPRESS

## FEATURES

- 4/12 mono/stereo streams of playback into 4 stereo outputs
- 8 mono/stereo streams of record from 4 stereo inputs
- Formats include PCM, MPEG layer 2 and MP3 with sample rates to 96kHz
- MRX™ technology supports digital mixing of multiple stream formats and sample rates
- TSX™ time scaling allows compression/expansion of play streams by up to +/-20% with no pitch shift
- SSX™ mode for multichannel record, playback and mixing
- Balanced stereo analog inputs and outputs with levels to +24dBu
- 24bit ADC and DAC with 110dB SNR and 0.0015% THD+N
- SoundGuard™ transient voltage suppression on all I/O
- Short length PCI card format (6.6 inches/168mm)
- Up to 4 cards in one system
- Windows 2000, XP and Linux software drivers available

ASI6640 – SSX Multichannel Mode

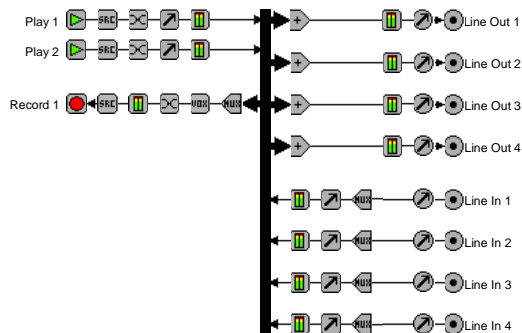

ASI6640 – Stereo/Mono Mode

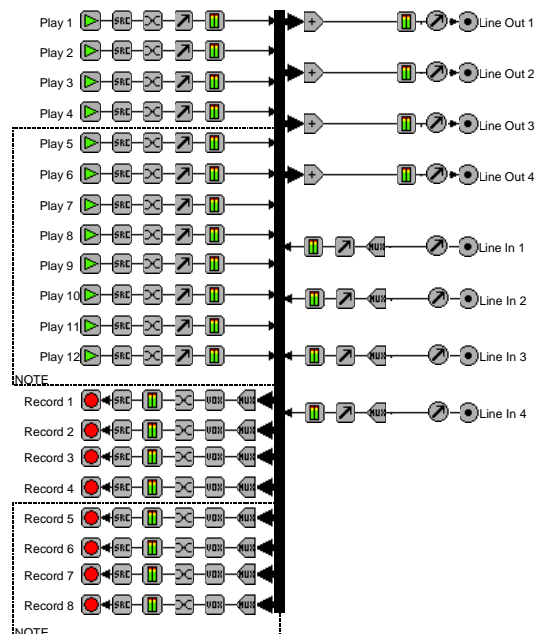

NOTE: Available in 12 Play/ 8 Record stream mode

## 1. SPECIFICATIONS

### ANALOG INPUT/OUTPUT

Type	Balanced
Connector	Mini50 (SCSI-II type)
Input Level	-10 to +24dBu in 0.5dBu steps
Input Impedance	10K ohms
A/D converter	24bit oversampling
Output Level	-10 to +24dBu in 0.5dBu steps
D/A converter	24bit oversampling
Load Impedance	600ohms or greater
Dynamic Range [1]	>110dB (record or play)
THD+N [1]	<-96dB (0.0015%) (record or play)
Frequency Response	20Hz to 20kHz +0/-0.2dB 20Hz to 40kHz +0/-3dB
Inter-channel Phase	<0.1 degrees (record or play)
Inter-channel Crosstalk	>110dB (record or play)

### SAMPLE RATE CLOCK

Internal	32, 44.1, 48, 88.2 and 96kHz
----------	------------------------------

### SIGNAL PROCESSING

DSP	Texas Instruments TMS320C6713@300MHz
Memory	8MB
Audio Formats	8 bit unsigned PCM 16 bit signed PCM 32 bit floating point PCM MPEG-1 Layer 2 MPEG-1 Layer 3 (MP3) (MPEG Layer-3 audio coding technology licensed from Fraunhofer IIS and THOMSON multimedia)

### BREAKOUT CABLES (NOT INCLUDED)

Analog	CBL1004: Mini 50 to Centronics 50 adapter. CBL1044: Centronics 50 to 8 in and 8 out XLR.
--------	---

### GENERAL

Bus	X1 PCI-Express.
Dimensions	PCI short-length form factor (6.6 inches/168mm long).
Weight	8 oz (227g) max
Operating Temperature	0C to 70C
Power Requirements	+3.3V@1.5A +12V @ 400mA

[1] – Dynamic Range and THD+N measured using a +20dBu 1kHz sine wave sampled at 48kHz and A weighting filter.

<end>